



PARTS LIST

CHAIN SAW

GZ4000

NOTE :

1. Use KOMATSU ZENOAH genuine parts specified in the parts list for repair and/or replacement.
2. KOMATSU ZENOAH does not warrant the machines, those which have been damaged by the use of any parts other than those specified by the company.
3. When placing orders of parts for repair and/or replacement, check if the model name and the serial number are suitable to those specified in the parts list, then use parts number described in the parts list.
4. The contents described in the parts list may change due to improvement.
5. The parts for the machine shall be supplied within ten (10) years after the machine is discontinued.
[It is possible that some specific parts may be subject to change of their delivery term and list price within the limit of ten (10) years after the machine is discontinued. And it is also possible that some parts may be available even after the limit of ten (10) years.]

Fig.1 POWER UNIT

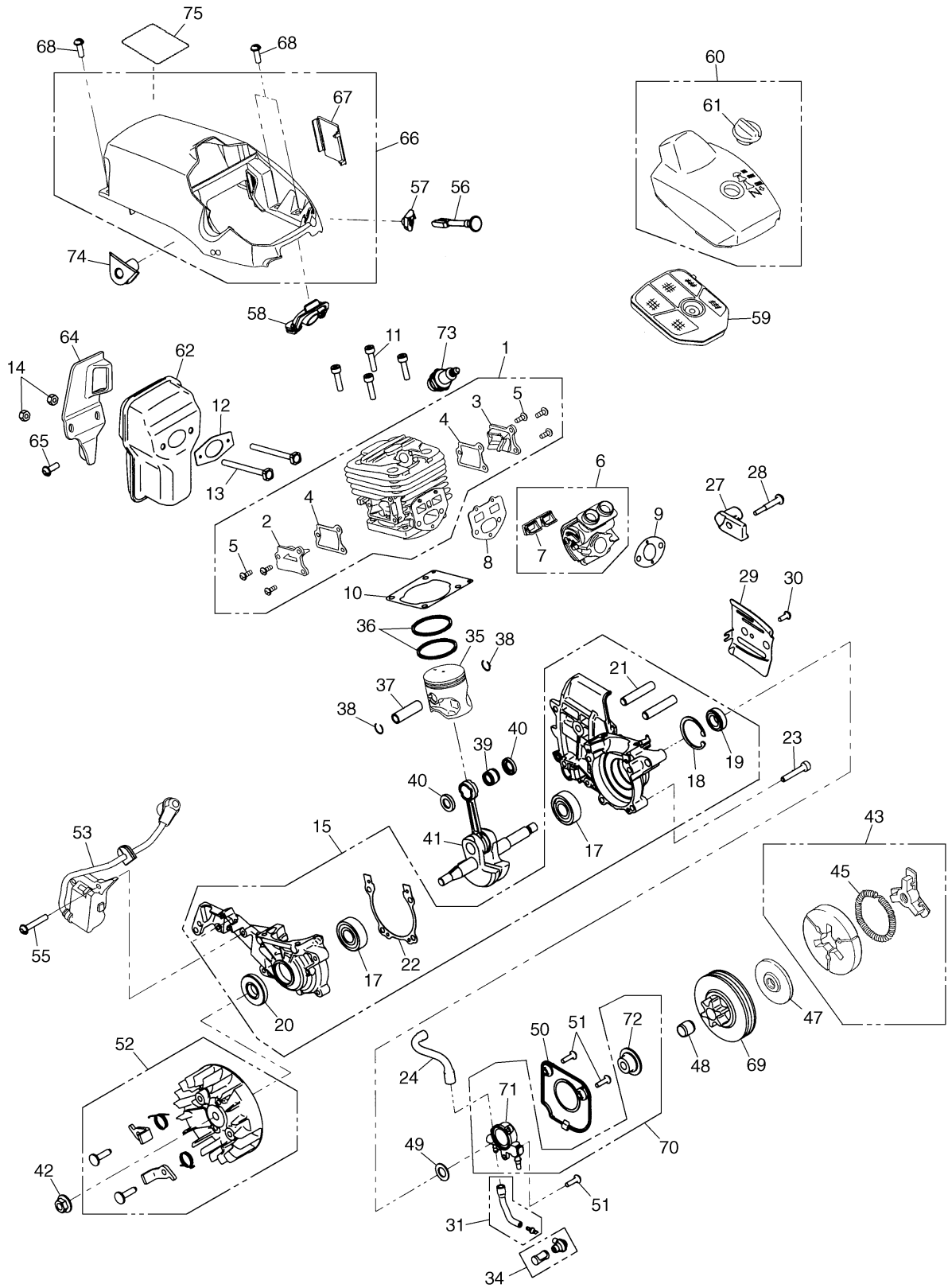

Fig.1 POWER UNIT

Key#	PART NUMBER	DESCRIPTION	Q'TY /UNIT	NOTE	Key#	PART NUMBER	DESCRIPTION	Q'TY /UNIT	NOTE
1	848C501211	CYLINDER ASSY	1		49	2850-55211	WASHER	1	
2	848C5012C1	• TR COVER MAG	1		50	T2100-55610	COVER	1	
3	848C5012D1	• TR COVER PTO	1		51	2670-55410	SCREW	4	
4	848C5012E1	• GASKET	2		52	848C507111	ROTOR COMP.	1	
5	2670-25430	• SCREW	6		53	848C507121	COIL ASSY	1	
6	848C501401	INSULATOR ASSY	1						
7	848C5016F1	• SEAL	1		55	2670-55410	SCREW	2	
8	848C5014B1	GASKET	1		56	2850-82411	ROD	1	
9	3330-14121	GASKET, carb	1		57	T2100-82420	GROMMET	1	
10	2850-14212	GASKET, cyl	1		58	T2100-82520	GROMMET	1	
11	4820-13180	BOLT	4		59	848C508300	CLEANER ASSY	1	
12	T2100-15210	GASKET	1		60	848C508321	COVER COMP.	1	
13	T2100-15220	BOLT	2		61	2841-83320	• KNOB	1	
14	2850-15230	NUT	2		62	T2100-15112	MUFFLER	1	
15	848C402102	CASE ASSY	1						
	-	• PIN	3		64	T2100-15311	STAY	1	
17	84889C3200	BEARING	2		65	2670-14320	SCREW	1	
18	04065-03212	SNAP RING	1		66	848C503111	COVER COMP.	1	
19	2169-21210	SEAL	1		67	2856-31120	• CAP	1	
20	8488AC3210	SEAL	1		68	8488251911	SCREW	4	
21	2616-21230	STAD	2		69	2851-51111	DRUM 0.325-7	1	
22	T2100-21310	GASKET	1		70	848C416702	OIL PUMP ASSY	1	
23	4820-21310	BOLT	4		71	848C1067A3	• OIL PUMP	1	
24	T2100-21400	PIPE OUT COMP.	1		72	2851-55121	• WORM	1	
	-	• PIPE	1		73	3699-91809	SPARK PLUG	1	
	-	• PIN	1		74	2867-82320	GROMMET	1	
27	848C3066F1	CATCHER, chain	1		75	848C5190F0	LABEL	1	
28	2850-25220	SCREW	1						
29	2850-25411	PLATE	1						
30	2670-25430	SCREW	1						
31	848C306732	PIPE IN COMP.	1						
	-	• PIPE IN	1						
	-	• JOINT	1						
34	T2100-23200	FILTER COMP.	1						
35	848C5041A1	PISTON	1						
36	2660-41211	RING	2						
37	T2128-41310	PIN	1						
38	1300-41320	RING	2						
39	T2100-41410	BEARING	1						
40	2850-41510	WASHER	2						
41	T2128-42000	SHAFT COMP.	1						
42	1650-43230	NUT	1						
43	848C405121	CLUTCH ASSY	1						
	-	• SHOE	3						
45	2870-51230	• SPRING	1						
	-	• BOSS	1						
47	2850-51211	PLATE	1						
48	3310-51310	BEARING	1						

Fig.2 POWER UNIT

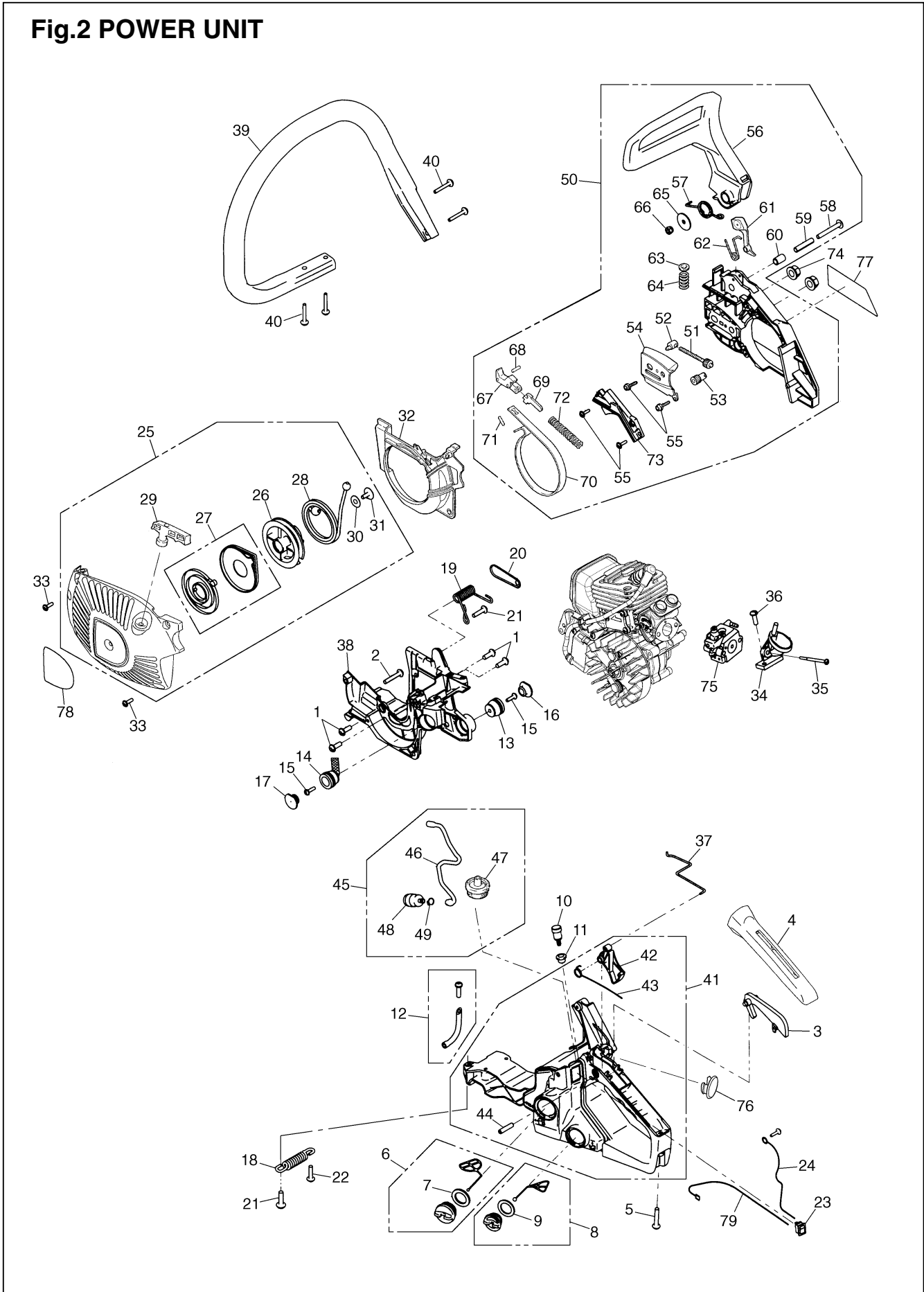
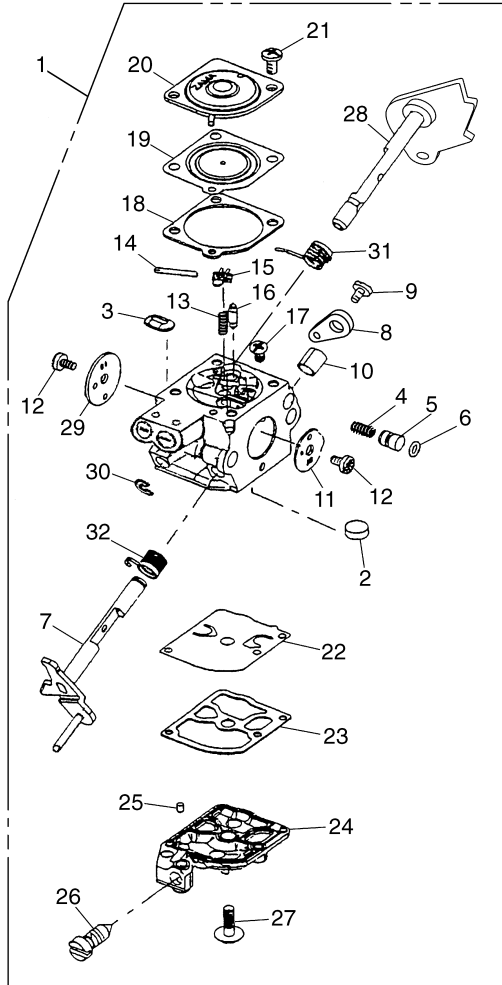

Fig.2 POWER UNIT

Key#	PART NUMBER	DESCRIPTION	Q'TY /UNIT	NOTE	Key#	PART NUMBER	DESCRIPTION	Q'TY /UNIT	NOTE
1	2670-14320	SCREW	4		49	1260-85460	• CLIP	1	
2	8488251911	SCREW	1		50	T2128-54000	BRAKE ASSY	1	
3	848C3033E3	ARM	1		51	2671-53210	• SCREW	1	
4	T2128-34110	COVER	1		52	2810-53221	• NUT	1	
5	8488252711	SCREW	1		53	2671-53230	• GEAR	1	
6	2670-34401	TANK CAP	1		54	2850-53250	• PLATE	1	
7	2670-34430	• GASKET	1		55	2670-54630	• SCREW	4	
8	2877-31800	CAP ASSY	1		56	2850-54111	• GUARD	1	
9	2841-31820	• GASKET	1		57	2850-54120	• SPRING	1	
10	2850-34501	BREATHER ASSY	1		58	2850-54130	• SCREW	1	
11	3317-85120	GROMMET	1		59	2850-54140	• SPACER	1	
12	T2100-31500	PIPE COMP.	1		60	2850-54211	• SPACER	1	
13	2616-35141	DAMPER	1		61	848C605423	• WEIGHT	1	
14	T2100-35200	DAMPER COMP.	1		62	2872-54230	• SPRING	1	
15	8488251601	SCREW	2		63	2851-54260	• PLATE	1	
16	2856-35180	CAP (T)	1		64	2851-54270	• SPRING	1	
17	2880-35250	CAP	1		65	3330-75411	• WASHER	1	
18	T2100-35110	SPRING F	1		66	3310-53331	• NUT	1	
19	T2100-35150	SPRING R	1		67	2851-54301	• LEVER COMP.	1	
20	T2102-35160	PLATE	1		68	2851-54350	• ROLLER	1	
21	8488251901	SCREW	2		69	2670-54411	• ARM	1	
22	2670-14320	SCREW	1		70	2851-54510	• BAND	1	
23	2850-74102	SWITCH ASSY	1		71	3356-24140	• ROLLER	1	
24	T2100-74210	CORD	1		72	2670-54610	• SPRING	1	
25	848C507501	STARTER ASSY	1		73	2850-54626	• COVER	1	
26	2850-75211	• REEL	1		74	3350-53410	NUT	2	
27	2850-75301	• SPRING COMP.	1		75	848C508101	CARBURETOR ASSY	1	
28	3317-75410	• ROPE	1		76	2851-33510	CAP	1	
29	3330-75421	• KNOB	1		77	848C5190B0	LABEL	1	
30	1400-86280	• WASHER	1		78	848C5190C0	LABEL	1	
31	8488251901	• SCREW	1		79	T2102-71510	CORD	1	
32	T2100-75610	COVER	1						
33	8488251911	SCREW	3						
34	2850-82114	MANIFOLD	1						
35	2867-82210	BOLT	2						
36	8488251911	SCREW	1						
37	T2100-82512	ROD	1						
38	T2100-25111	CASE	1						
39	848C5032A1	HANDLE	1						
40	8488252711	SCREW	4						
41	T2100-33000	HANDLE ASSY	1						
42	2850-33313	• LEVER	1						
43	3356-33321	• SPRING	1						
44	04025-00524	• SPRING PIN	1						
45	T2100-34301	PIPE ASSY	1						
46	2850-34311	• PIPE	1						
47	2851-34321	• GROMMET	1						
48	1850-85300	• FILTER	1						

Fig.3 CARBURETOR COMPONENTS



Key#	PART NUMBER	DESCRIPTION	Q'TY /UNIT	NOTE
1	848C508101	CARBURETOR ASSY	1	
2	848C5081A0	• STRAINER	1	*
3	848C5081J0	• PLUG	1	*
4	848C5080M0	• SPRING	1	
5	848C5080N0	• PLUNGER	1	
6	848C5080P0	• O-RING	1	
7	848C5081T0	• SHAFT, throttle	1	
8	848C5081Z0	• LEVER, throttle	1	
9	848C5080R0	• SCREW	1	
10	848C5081S0	• COLLAR	1	
11	848C5081U0	• VALVE, throttle	1	
12	848C5081W0	• SCREW	2	
13	848C5081C0	• SPRING	1	*
14	848C5081E0	• PIN	1	*
15	848C5081F0	• LEVER	1	*
16	848C5081B0	• VALVE	1	*
17	848C5081D0	• SCREW	1	
18	848C5081L0	• GASKET	1	*
19	848C5081K0	• DIAPHRAGM	1	*
20	848C5081G0	• COVER	1	
21	848C5080B0	• SCREW	2	
22	848C5081M0	• DIAPHRAGM, pump	1	*
23	848C5081N0	• GASKET, pump	1	*
24	848C5081H0	• COVER, pump	1	
25	848C5081Y0	• PIECE, friction	1	
26	848C5081X0	• SCREW, idle	1	
27	848C5081P0	• SCREW	1	
28	848C5080E0	• SHAFT, choke	1	
29	848C5080C0	• VALVE, choke	1	
30	848C5080A0	• E-RING	1	
31	848C5080D0	• SPRING, choke	1	
32	848C5081R0	• SPRING, throttle	1	

Fig.4 ACCESSORIES

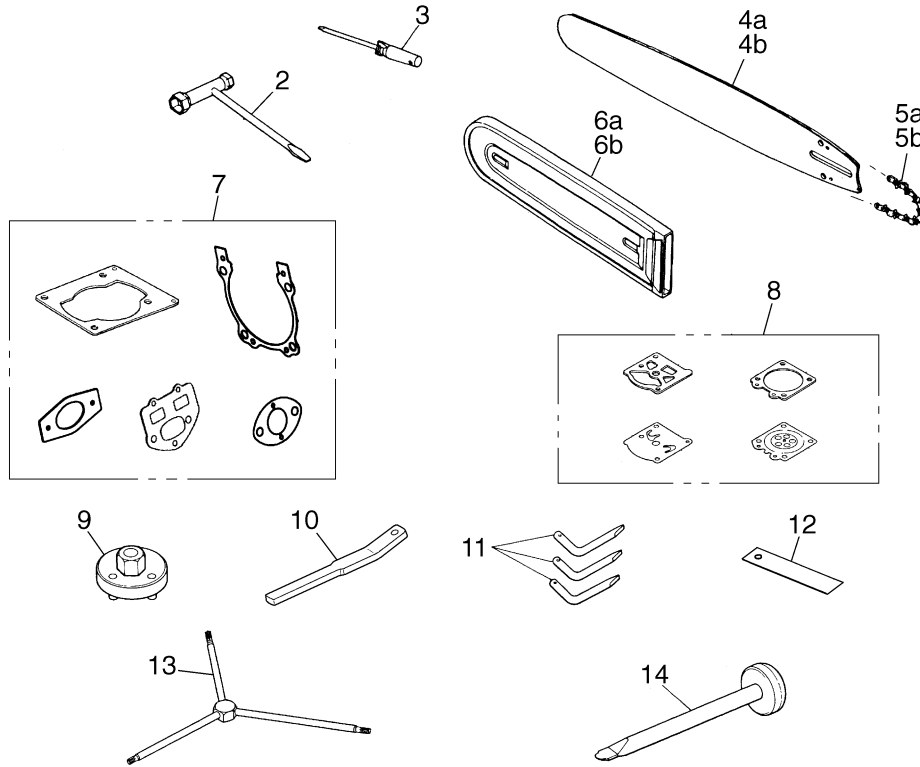

Key#	PART NUMBER	DESCRIPTION	Q'TY /UNIT	NOTE
2	8488U10010	Plug 13x16	1	
3	2670-91150	Driver	1	
4a	2939-52110-50	Sprocket nose bar 16"	1	
4b	848CB44C10	Sprocket nose bar 14"	1	
5a	3699-91241	Chain for 16" bar	1	(95VP-66E)
5b	3699-91577	Chain for 14" bar	1	(95VP-60E)
6a	3356-97110	Protector for 16" bar	1	
6b	3617-97110	Protector for 14" bar	1	
7	848C500610	Gasket kit	1	(OP)
8	848C500620	Gasket kit	1	(OP)
9	2670-96210	Wrench (for clutch)	1	(OP)
10	8488W20010	Stopper (for piston)	1	(OP)
11	2670-96240	Wrench (for clutch ASSY)	3	(OP)
12	3330-97310	Gauge (for air gap)	1	(OP)
13	2850-96410	Wrench (T20xT25xT27)	1	(OP)
14	2670-96510	Guide (for break spring)	1	(OP)



KOMATSU ZENOAH CO.

1-9 Minamidai, Kawagoe, Saitama, 350-1192 Japan

PRINTED IN JAPAN

PRINTED ON RECYCLED PAPER
IMPRIMÉ SUR PAPIER RECYCLÉ
GEDRUCKT AUF RECYCLING PAPIER
STAMPATO SU CARTA RICICLATA
IMPRESO EN PAPEL RECICLADO